

Monterings- och bruksanvisning

Hyllställ

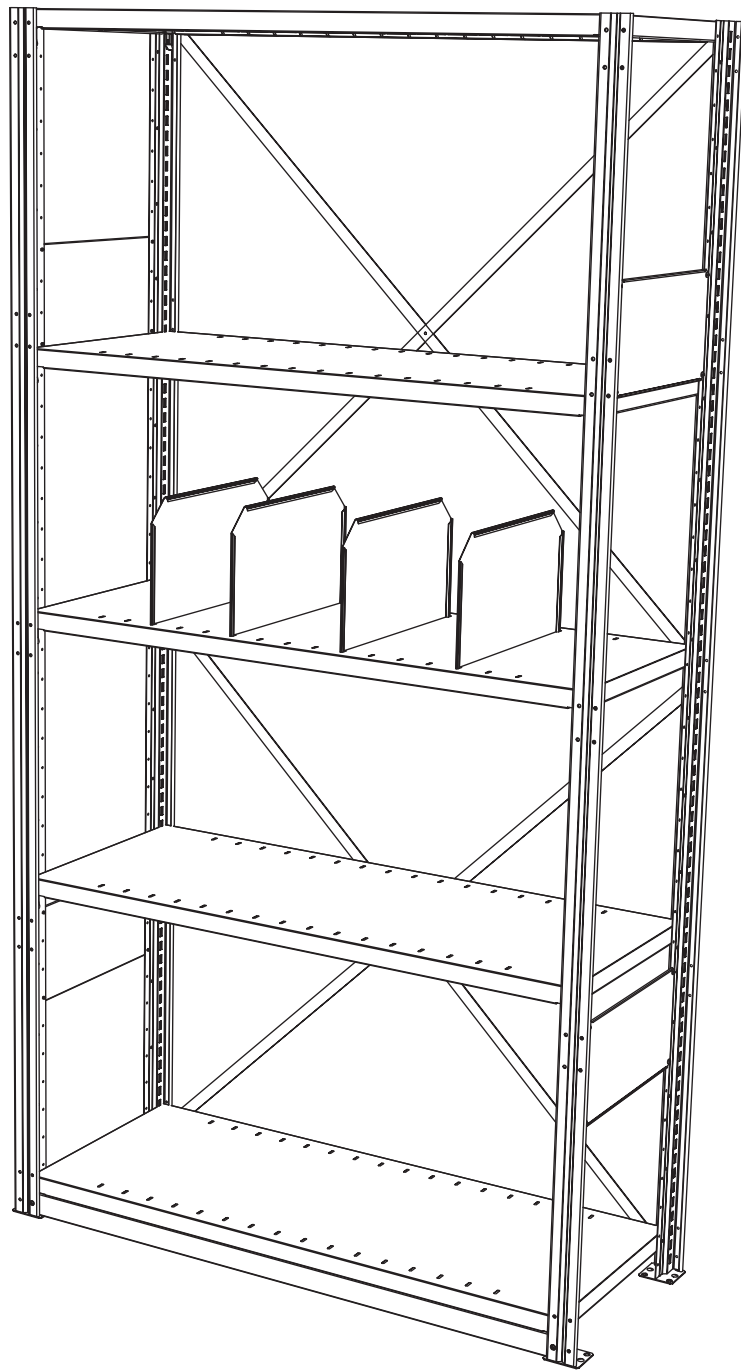

GAVEL MED STAGPLÅT

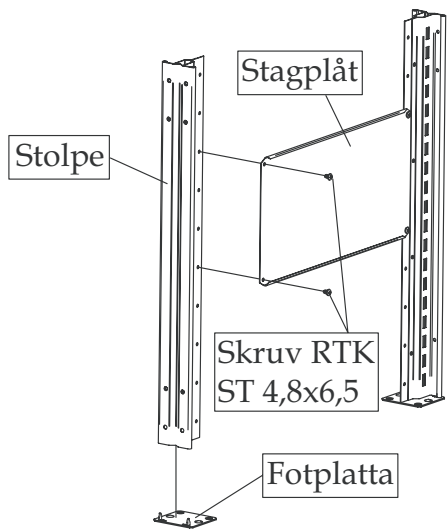

Placering av stagplåtar

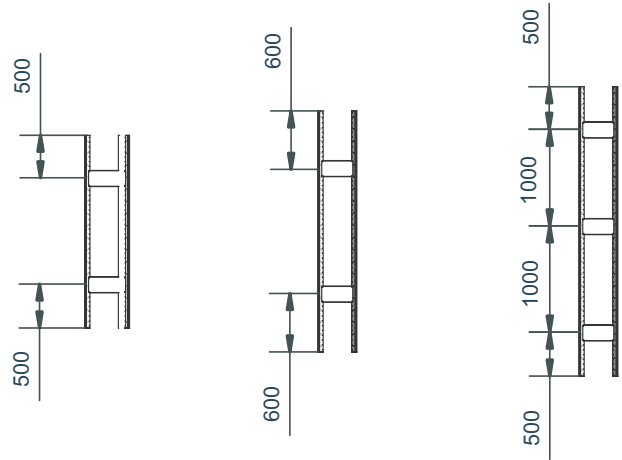

Gavelhöjd 2 m Gavelhöjd 2,5 m Gavelhöjd 3 m

GAVEL MED PANEL

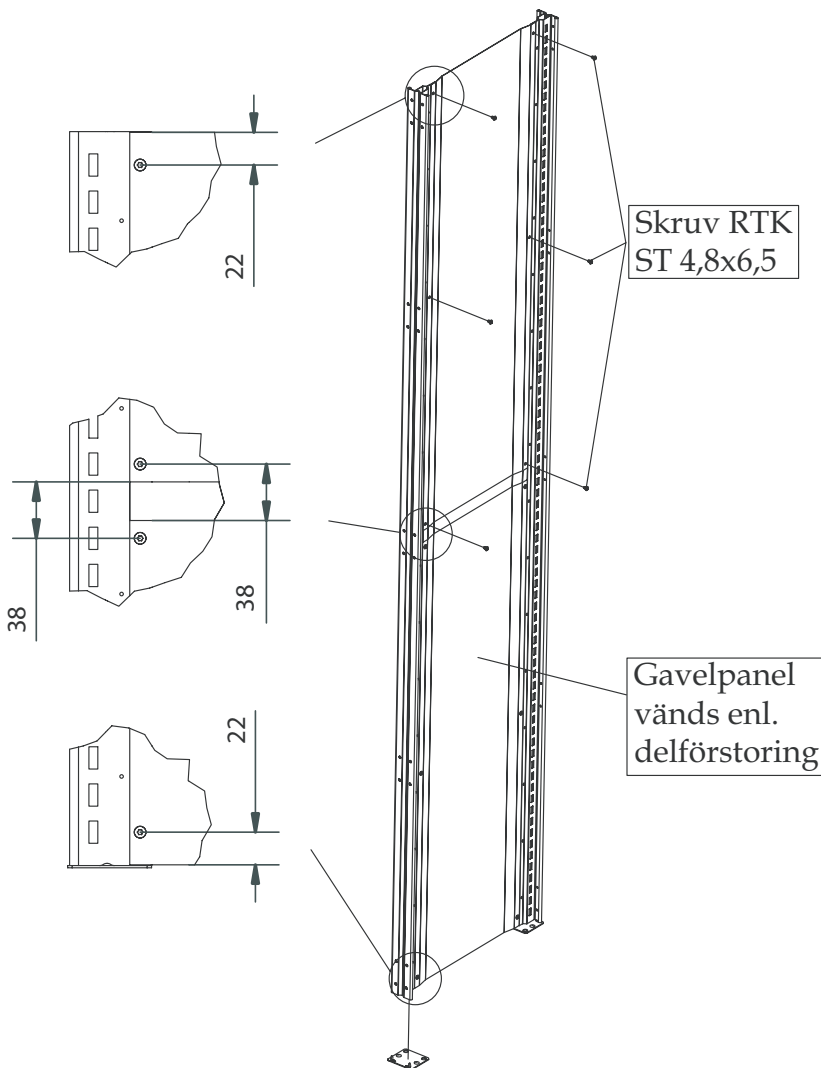

HYLLPLAN

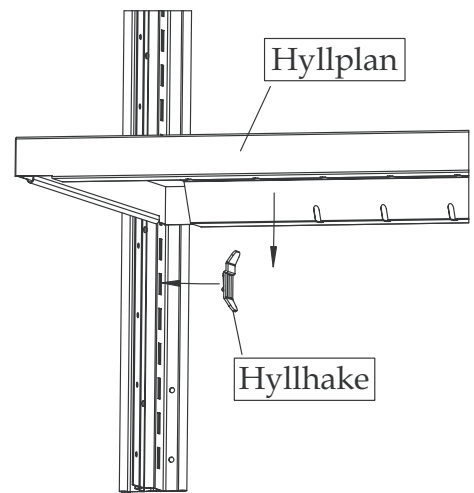

RYGGSTAGSKRYSS

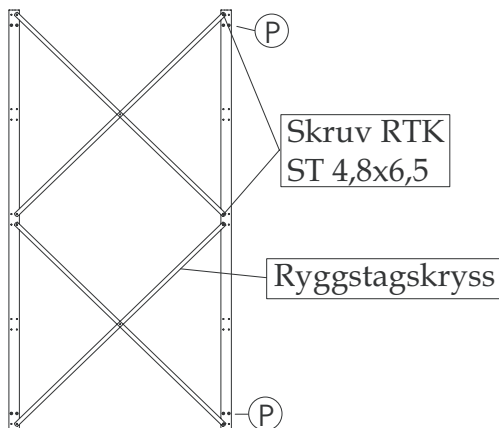

Gavelhöjd 2 m

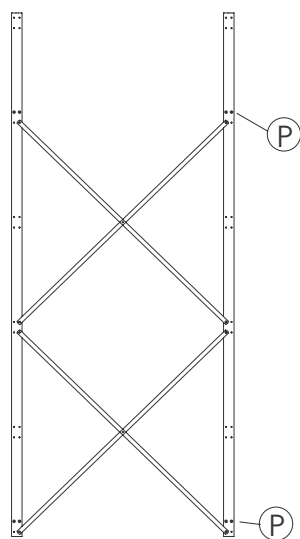

Gavelhöjd 2,5 m

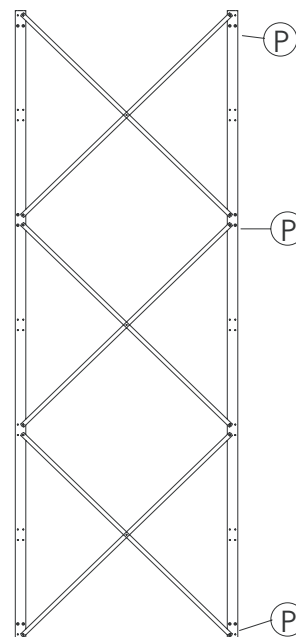

Gavelhöjd 3 m

Ⓟ = Plastbricka vid dubbelställ

Vid max belastning 1500 kg/sektion sker ryggstagning enligt följande mönster, vid andra belastningsfall kontakta EAB.
Vid dubbelställ används gemensamt kryss.

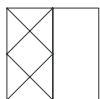

1-3 Sektioner

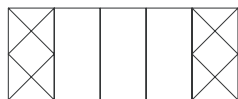

4-6 Sektioner

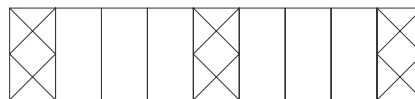

7-9 Sektioner

DUBBELSTÄLL

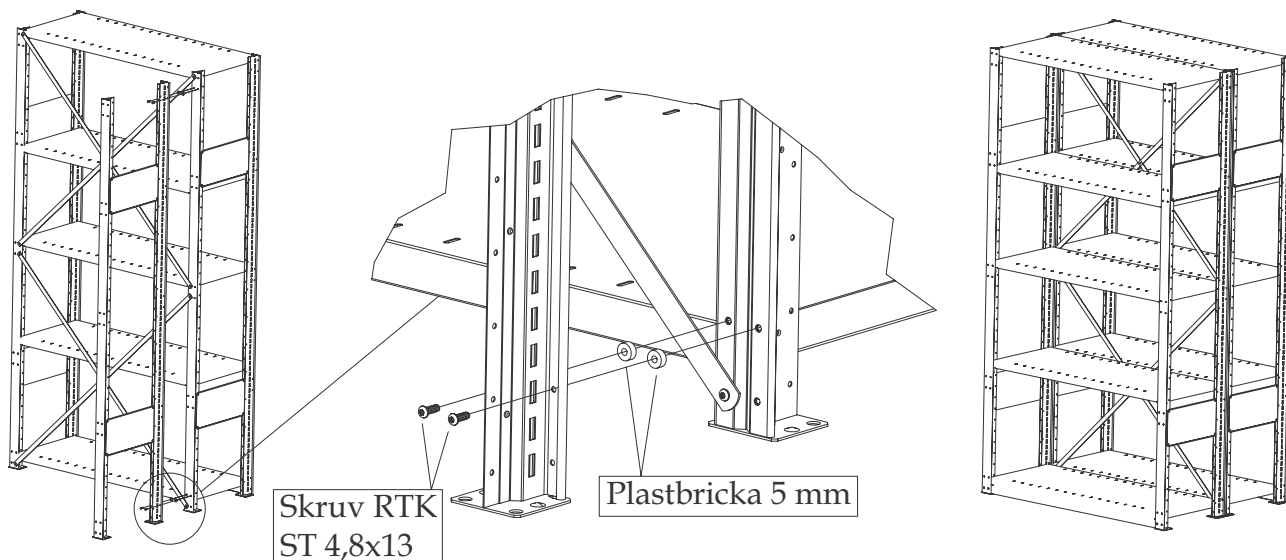

RYGGPANEL

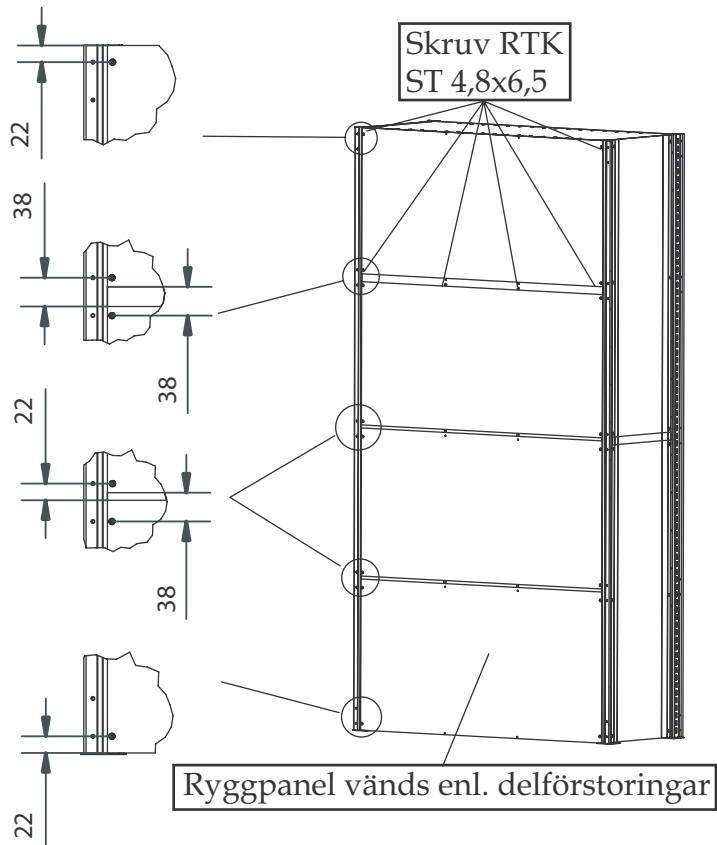

SOCKELPLÅT

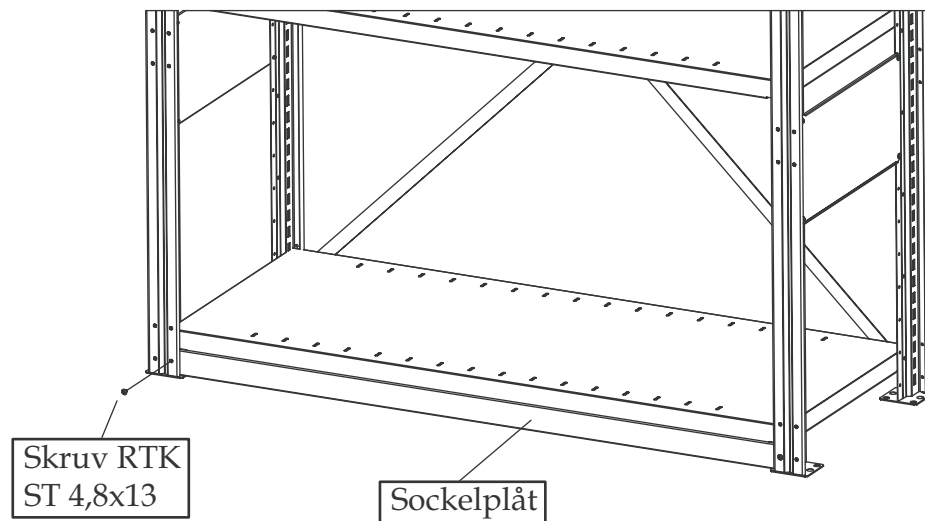

SKRUV

Vid montering används Torxskruv RTK ST 4,8x6,5 T20 FZB och Torxskruv RTK ST 4,8x13 T20 FZB. Bits torx T-20



LAGERINREDNINGAR PORTAR STÅLBYGGNADER
333 33 SMÅLANDSSTENAR
TEL 0371-340 00 FAX 0371-312 25
E-MAIL info@eab.se INTERNET www.eab.se